

## ASIA PACIFIC - AUSTRALIA

Level 5, 600 Bourke Street,  
Melbourne, VIC 3000  
+61 3 9236 2311

COPYRIGHT O-1 OPERATIONS (AUSTRALIA) PTY LTD ("O-1").  
MUST NOT BE COPIED IN WHOLE OR PART WITHOUT WRITTEN  
PERMISSION FROM O-1. THIS DRAWING CONTAINS  
INFORMATION WHICH IS CONFIDENTIAL TO O-1 AND MUST  
BE USED ONLY AS DIRECTED BY O-1. THIS DRAWING MUST  
NOT BE DISCLOSED TO ANYONE WITHOUT THE WRITTEN  
CONSENT OF O-1. CUSTOMER HEREBY INDEMNIFIES AND  
HOLDS O-1 HARMLESS FOR ANY LOSS, DAMAGE OR LIABILITY  
WHICH O-1 MAY INCUR IF THE DESIGN, MANUFACTURE AND  
SUPPLY OF THE CONTAINERS IN ACCORDANCE WITH THE  
INSTRUCTIONS OR REQUIREMENTS OF CUSTOMER INFRINGES  
THE INTELLECTUAL PROPERTY RIGHTS OF ANY THIRD PARTY.

SPECIFICATION AGREEMENTS ARE BASED ON TOLERANCED  
DIMENSIONS ONLY.  
ALL DIMENSIONS IN MILLIMETRES (mm).

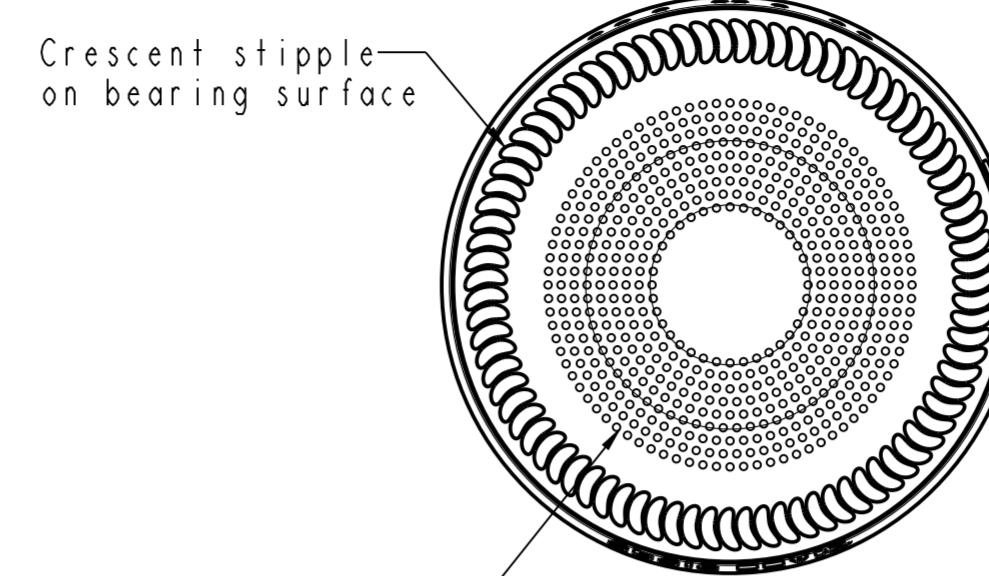
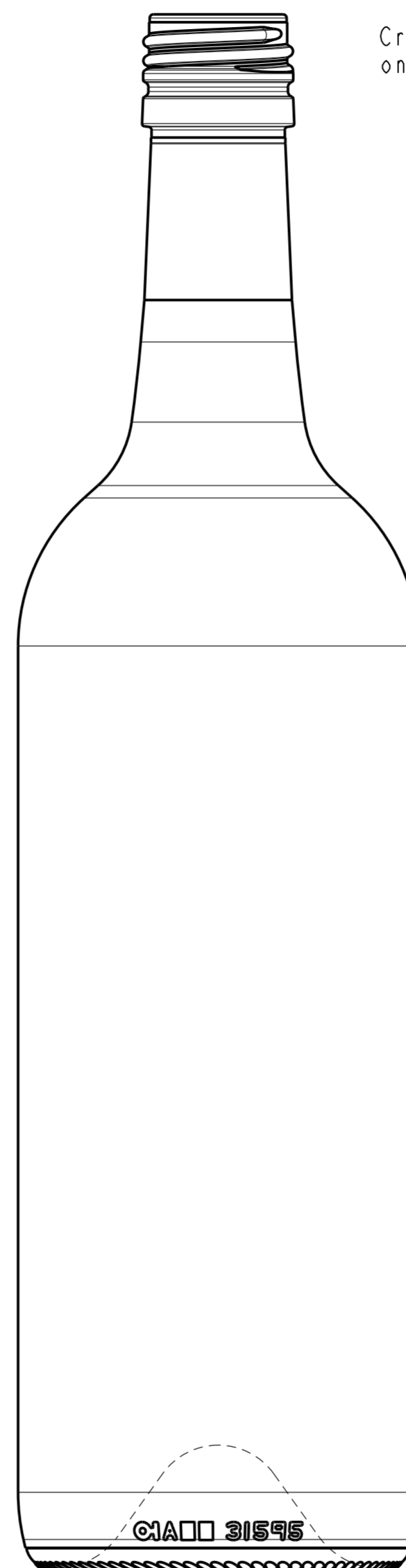
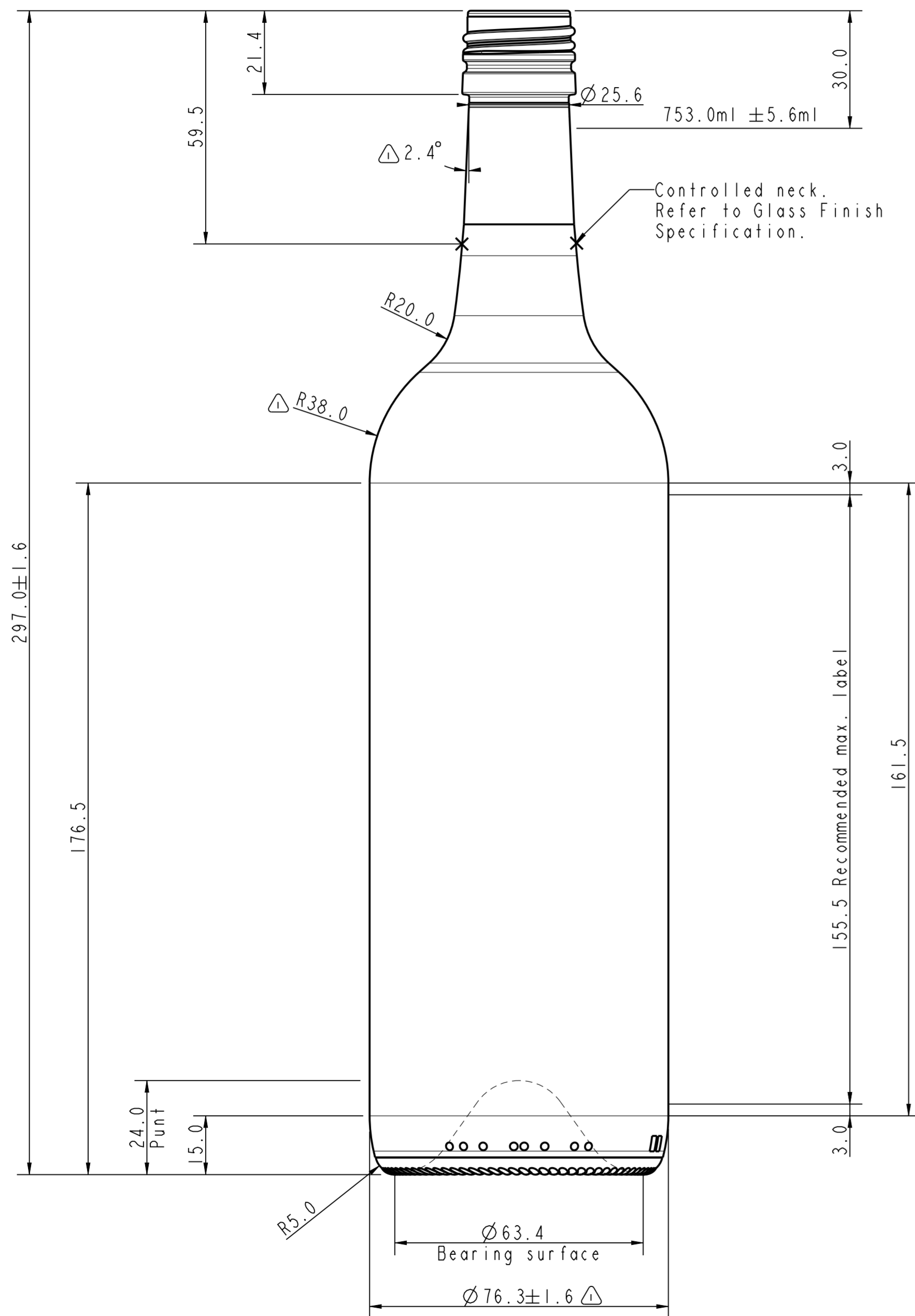

GT-2 Stipple (optional)



Note:  
This container has a 2.0 max. gas volume rating for flint and artie blue only.

NPNB EQUIVALENT		N/A	
MOULD EQUIPMENT ORDERED BY:			
PLANT			
N.P.D. PROJECT NUMBER	NPDI225	SCALE	1:1
VACUITY	1.2%	TILT ANGLE	PREDICTED: $15.75^\circ$
SURFACE TREATMENT	PERMANENT	VERIFIED:	
MINIMUM THROUGH BORE	17.5 mm	BRIMFUL VERIFIED	NO
CONTAINER OVERFLOW CAPACITY ( BRIMFUL )			
762.0ml Approx.			
CONTAINER RATED CAPACITY ( FILL CAPACITY )			
$753.0\text{ml} \pm 5.6\text{ml}$			
CONTAINER WEIGHT			
465g			
FINISH DESIGNATION		MAX. GAS VOLUME	
30mm x 60 CETIE BVS [GRP-29394]		0.0 SEE NOTE	
PROCESS	RETURNABLE	DESIGN REF.	
B&B	NO	01_3080_750	

### Stock

750ml BVS Punted Bordeaux

DESIGNER	YS Ong	DATE	14 MAY 18
CHECKED	T Tran	DATE	17 MAY 18

DRAWING NUMBER  
**31595-WS**

MOULD NUMBER  
**31595**

No	DATE	REVISIONS	DESIGN/CHECK
1	06 Sep 18	Overall diameter was 76.1mm. Neck dimension was $3.0^\circ$ and R40.0.	YS/TT