

CUSTOMER APPROVAL

Cust Name	
Cust Signature	
Approval Date	

Customer Capacity	750mL
Fill Point Volume	753mL ± 5.5mL Nom @ 30mm
Brimful Volume	762mL
Weight	360g
Max. Gas Volumes	1.8*
Tilt Angle	18.6°
Process	NNPB & BB

* Gas rating only applies to AB

The WPA recommend that the label should be positioned at a minimum of 5mm above the bottom of the designated label panel and a minimum of 5mm below the top of the designated label panel with a maximum label height that is equal to or less 10mm than is shown as the designated label panel height on the glass drawing

Customer Specifications - Orora Glass



Number	AG111_R01	C	Artic Blue gas rating added	08/02/2017
Description	750mL BVS Burgundy	B	Previously only NNPB	17/07/2015
Date & Revision	08/02/2016 Revision C	A	Pressure rating added	27/08/2012
Finish	R01 CMP - 30x60 BVS	Initial	Previously SD33/10	09/12/2010
		Rev	Description	Date

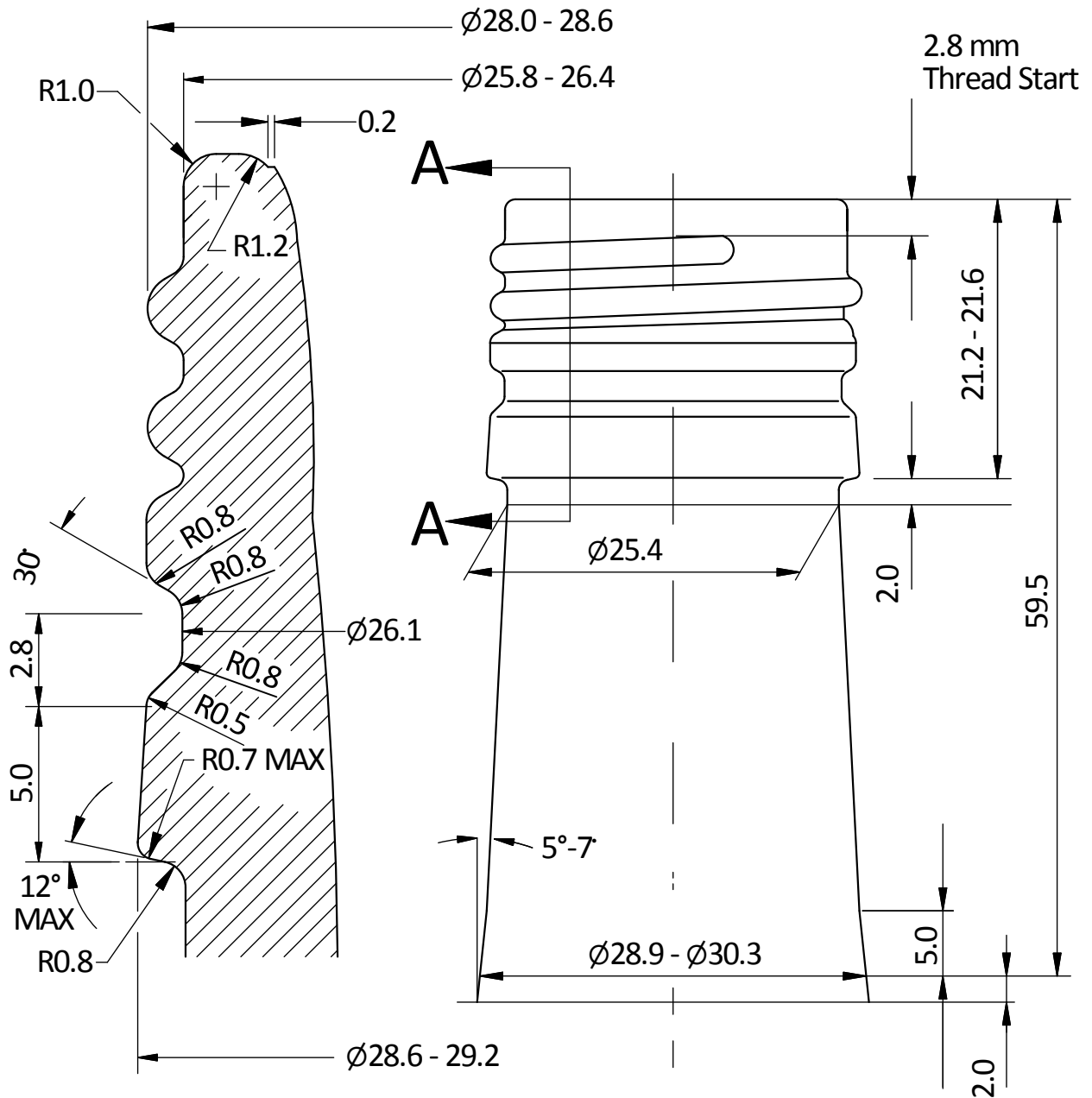

SECTION A-A

THREAD DETAIL

PITCH 3.63

Minimum through bore diameter is 17.50mm

Customer Specifications - Orora Glass



Finish Number R01 CMP

Description 30 x 60 BVS Finish with take-out groove - Closed Mould Pick-up

Date & Revision 02/09/2013 Rev B