

CUSTOMER APPROVAL

Cust Name	
Cust Signature	
Approval Date	

Customer Capacity	750mL
Fill Point Volume	753mL ± 5.5mL Nom @ 30mm
Brimful Volume	762mL Nom
Weight	380g
Max. Gas Volumes	1.8
Gas Rated Colours*	AB
Tilt Angle	16.3°
Process	NNPB or B&B

* Colours not specified are not gas rated

The WPA recommend that the label should be positioned at a minimum of 5mm above the bottom of the designated label panel and a minimum of 5mm below the top of the designated label panel with a maximum label height that is equal to or less 10mm than is shown as the designated label panel height on the glass drawing

Customer Specifications - Orora Glass



Number	AG104_R01CMP	C	Process was only NNPB	22/12/2014
Description	750mL BVS Claret	B	Pressure rating added	27/09/2013
Date & Revision	22/12/2014 Revision C	A	P/U was 5.0	30/03/2011
Finish	R01 CMP 30x60 BVS	Initial	Previously SD07/10	16/02/2010
		Rev	Description	Date

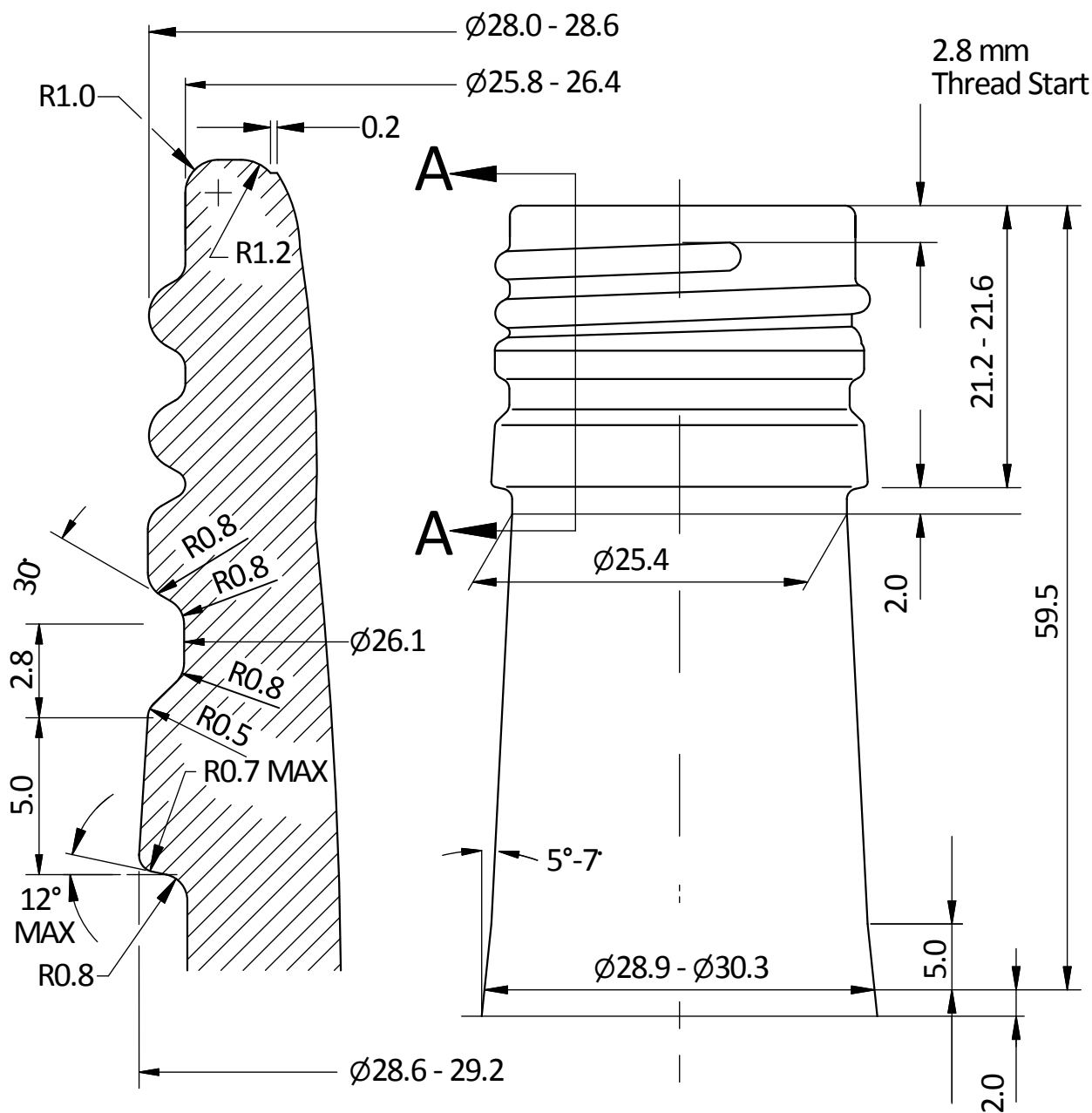

SECTION A-A

THREAD DETAIL

PITCH 3.63

Minimum through bore diameter is 17.50mm

Customer Specifications - Orora Glass



Finish Number R01 CMP

Description 30 x 60 BVS Finish with take-out groove - Closed Mould Pick-up

Date & Revision 02/09/2013 Rev B