

Crescent stipple on bearing surface

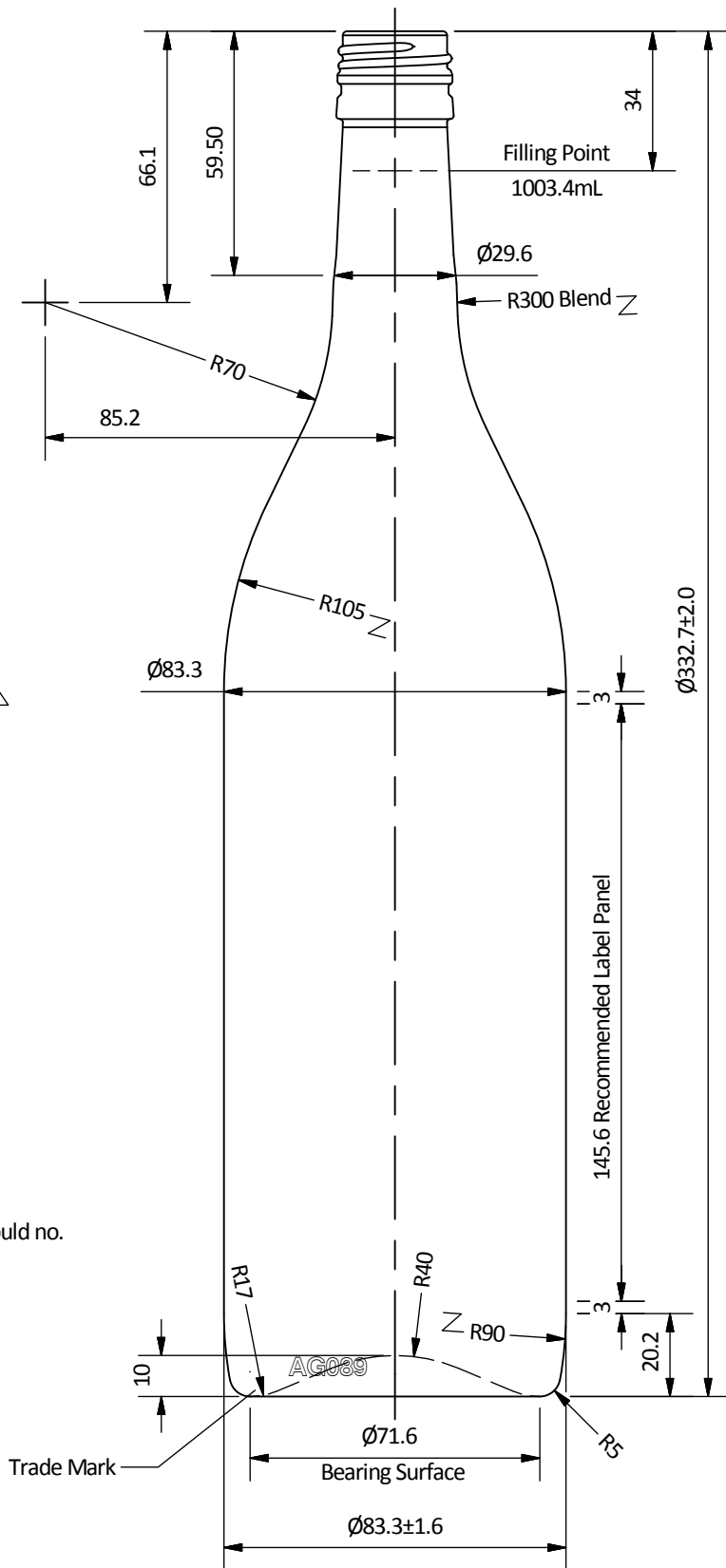
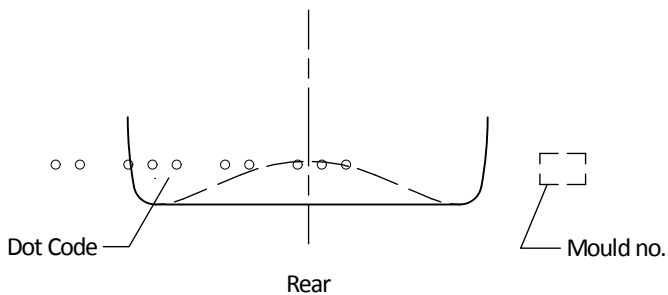

CUSTOMER APPROVAL

Cust Name	
Cust Signature	
Approval Date	

Customer Capacity	1000mL ± 6.8mL
Fill Point Volume	1003.4mL Nom @ 34mm
Brimful Volume	1014mL Nom
Weight	540g
Max. Gas Volumes	TBA
Tilt Angle	16.9°
Process	BB

Customer Specifications - Orora Glass



Number	AG089_R01	B		
Description	1L BVS Wine	A		
Date & Revision	14/10/2015 Initial	Initial	Based on AG079 - 540g Version	14/10/2015
Finish	R01 CMP - 30x60 BVS	Rev	Description	Date

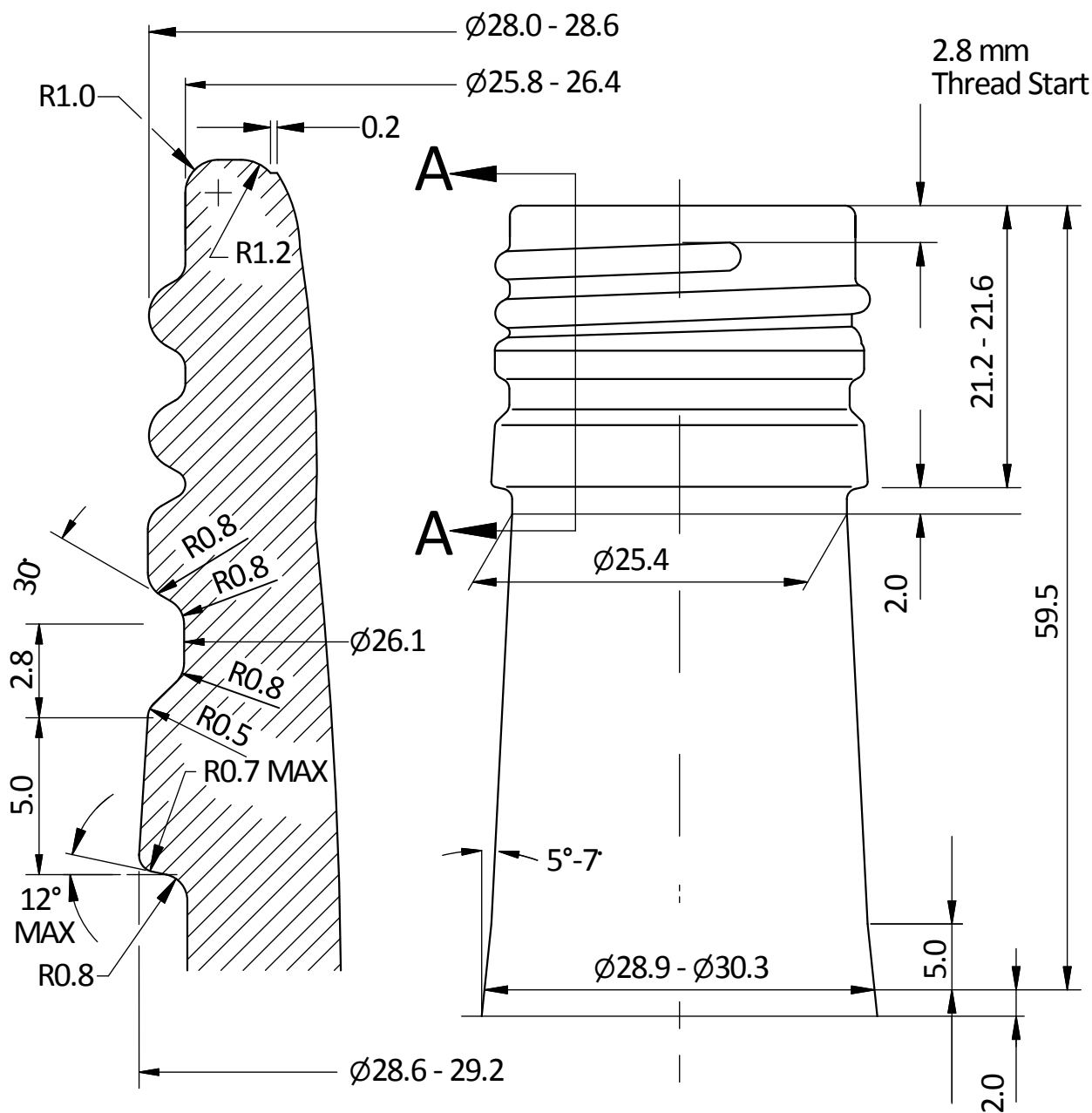

**SECTION A-A**

**THREAD DETAIL**

PITCH 3.63

Minimum through bore diameter is 17.50mm

Customer Specifications - Orora Glass



Finish Number R01 CMP

Description 30 x 60 BVS Finish with take-out groove - Closed Mould Pick-up

Date & Revision 02/09/2013 Rev B