

CUSTOMER APPROVAL

Cust Name	
Cust Signature	
Approval Date	

Customer Capacity	753mL
Fill Point Volume	753mL ± 5.5mL Nom @ 63mm
Brimful Volume	773mL Nom
Weight	445g
Max. Gas Volumes	TBA
Tilt Angle	16.9
Process	BB

The WPA recommend that the label should be positioned at a minimum of 5mm above the bottom of the designated label panel and a minimum of 5mm below the top of the designated label panel with a maximum label height that is equal to or less 10mm than is shown as the designated label panel height on the glass drawing\*

Customer Specifications - Orora Glass



Number	AG088_C02	B		
Description	750mL CR Punted Claret	A	Dimensions for Neck Label Added	01/12/2011
Date & Revision	01/12/2009 Revision A	Initial	Previously SD03/09	02/09/2009
Finish	C02 - Plain Band Cork Mouth	Rev	Description	Date

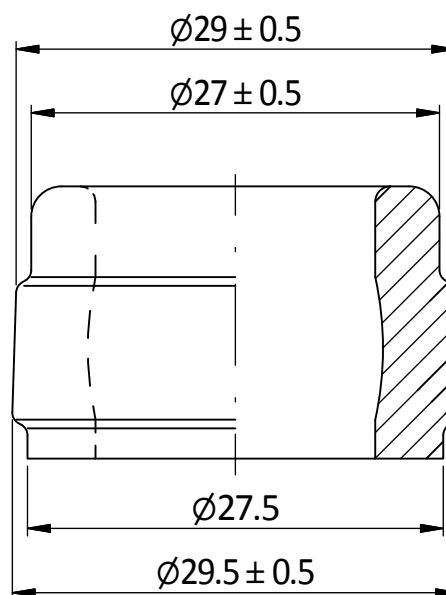
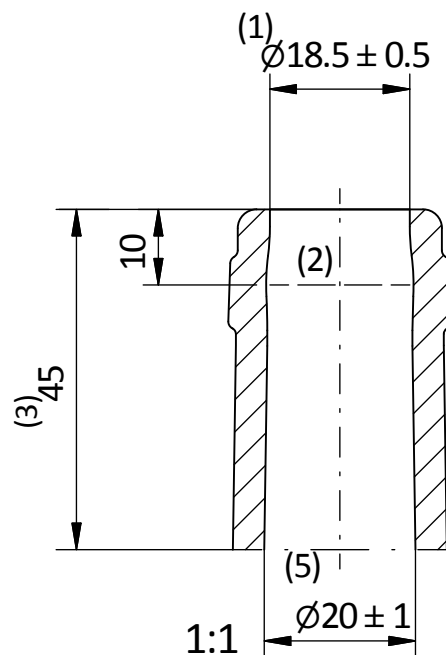

2:1

**BORE CONTROL**

1. Mean bore entry is measured at 3mm from the top
2. Mean bore diameter at 10 mm is to be no larger than 1.0 mm greater than that at entry
3. Mean diameter at 45 mm is  $20 \text{ mm} \pm 1 \text{ mm}$
4. The mean bore diameter for 45 mm must not be smaller than the bore at entry
5. The minimum through bore diameter is 17.5 mm

Customer Specifications - Orora Glass



Finish Number C02

Description Plain Band Cork Mouth Finish

Date &amp; Revision 03/03/2004 Revision A