

CUSTOMER APPROVAL

Cust Name	
Cust Signature	
Approval Date	

Customer Capacity	750mL
Fill Point Volume	753mL ± 5.5mL Nom @ 30mm
Brimful Volume	762mL Nom
Weight	415g
Max. Gas Volumes	2
Tilt Angle	18.7°
Process	BB

*Gas rating applies only to AB

The WPA recommend that the label should be positioned at a minimum of 5mm above the bottom of the designated label panel and a minimum of 5mm below the top of the designated label panel with a maximum label height that is equal to or less 10mm than is shown as the designated label panel height on the glass drawing

Customer Specifications - Orora Glass



Number	AG086_R01	C	Gas ratings updated	10/07/2014
Description	750mL Low Carb BVS Burgundy	B	Finish was R01. Punt & Shoulder corrected	29/10/2013
Date & Revision	10/07/2014 Revision C	A	Internal Gas Rating Added	27/09/2013
Finish	R01 CMP 30x60 BVS	Initial	Was SD47/10	02/08/2011
		Rev	Description	Date

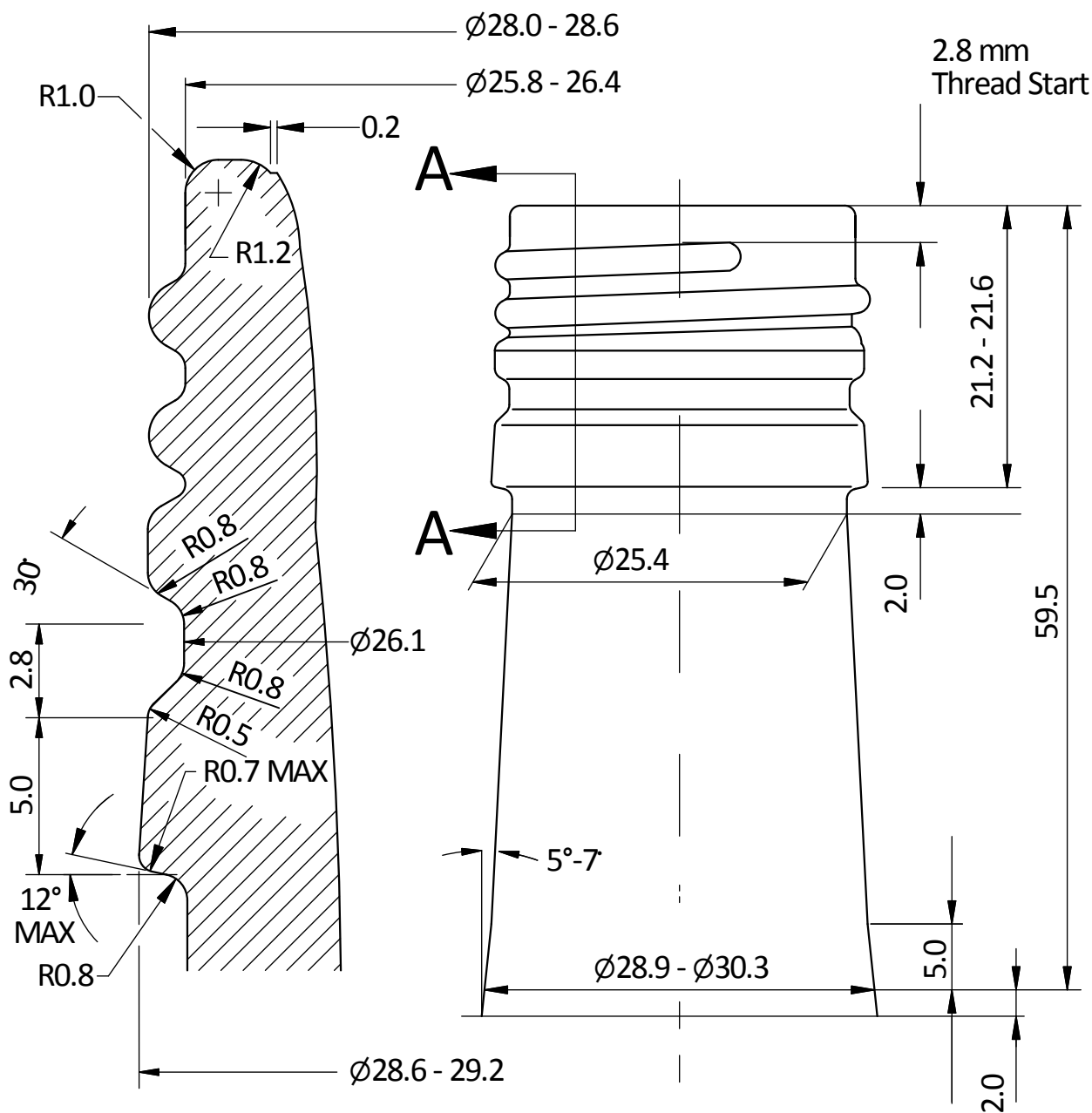

SECTION A-A

THREAD DETAIL

PITCH 3.63

Minimum through bore diameter is 17.50mm

Customer Specifications - Orora Glass



Finish Number R01 CMP

Description 30 x 60 BVS Finish with take-out groove - Closed Mould Pick-up

Date & Revision 02/09/2013 Rev B