

CUSTOMER APPROVAL

Cust Name	
Cust Signature	
Approval Date	

Customer Capacity	750mL
Fill Point Volume	753mL ± 5mL Nom @ 30mm
Brimful Volume	762mL Nom
Weight	732g
Max. Gas Volumes	TBA
Tilt Angle	15.9°
Process	BB

The WPA recommend that the label should be positioned at a minimum of 5mm above the bottom of the designated label panel and a minimum of 5mm below the top of the designated label panel with a maximum label height that is equal to or less 10mm than is shown as the designated label panel height on the glass drawing

Customer Specifications - Orora Glass



Number	AG027_R01	D	Alignment cleft added	22/03/2012
Description	750mL Super Premium BVS Bordelaise	C	Overall height corrected to 329mm	27/08/2010
Date & Revision	15/08/2012 Revision D	Initial		
Finish	R01 - 30x60 BVS	Rev	Description	Date

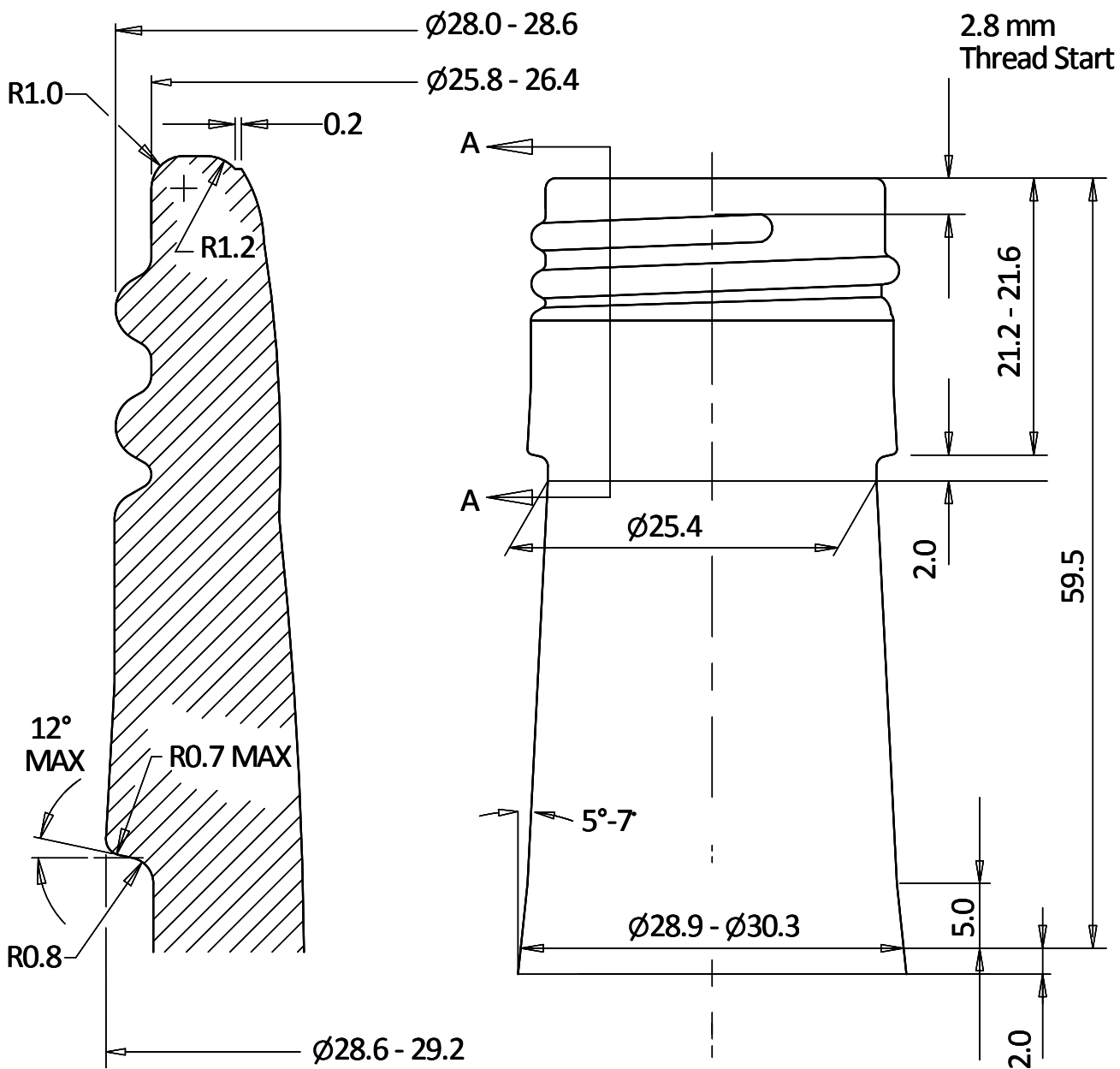

SECTION A-A

THREAD DETAIL

PITCH 3.63

Minimum through bore diameter is 17.50mm

Customer Specifications - Orora Glass



Finish Number R01

Description 30 x 60 BVS Finish

Date & Revision 23/11/2010 Rev E